

PREMiA ES

PBP16 - 20N3(R)(E) & PBP12N2D Series

POWER PALLET TRUCK

1.2 - 2.0 tonnes

DESIGNED TO EXCEL
BUILT TO LAST

Developed for non-stop performance in the most challenging environments, PREMiA ES pedestrian power pallet trucks help you go the distance. Thanks to its sealed protective chassis and waterproof components (rated to IP54), PREMiA ES is unaffected by dirt, debris, dust, and water, working dependably indoors or out with minimal maintenance.

SPECIFICATIONS

PBP12N2D	PBP20N3
PBP16N3	PBP20N3R
PBP18N3	PBP20N3E



WHEN
RELIABILITY IS
EVERYTHING...

PREMI^A ES

PBP16 - 20N3(R)(E) & PBP12N2D Series

POWER PALLET TRUCK

1.2 – 2.0 tonnes

BRAKES

- **Parking brake**
Automatically activated when necessary for extra safety on ramps.
- **Regenerative braking**
Extends shift life and gives effective control without brake wear.

DRIVE

- **Sealed transmission**
Shock-resistant, quiet and requires little maintenance.
- **Powerful AC drive motor**
Excellent traction and ramp performance, smooth, quiet, controlled operation, extended shift length and lower maintenance requirements.
- **Sensitive Drive System (SDS)**
An intuitive driver-assist system for increased safety. Performance is managed according to steer angle and the velocity of foot and finger controls.

ELECTRICAL AND CONTROL SYSTEMS

- **Programmable controller**
Acceleration, speed and braking can be adjusted to suit the application and operator's preferences.
- **On-board diagnostics and fault memory folder**
Speed up servicing and help prevent damage.
- **Combi controller lift system**
Fingertip control for speed regulated lifting and proportional valve for lowering. (PBP12N2D)

FORKS AND MAST

- **Robust forks**
Strong welded construction with rounded tips for effortless pallet entry.
- **Market-leading lift height of 220mm**
Ideal for handling on steep ramps, loading docks and uneven surfaces, even when using recycled pallets.
- **Rising forks**
To minimise physical strain when loading and unloading, loads are placed at a more comfortable height for the operator (maximum height of 735mm). (PBP12N2D)
- **Tapered forks**
Access to pallets in racks or block stacks is easier, quicker and safer.

FRAME AND BODY

- **Sealed chassis**
Internal components are protected against water, dirt, dust and debris, reducing downtime and servicing.
- **Water-resistant design**
Water is kept away from key electrical parts for safety and longer part life.
- **Two linked castor wheels**
In addition to the load wheels for added stability. Increases comfort for the driver and safety for the load.
- **Low centre of gravity**
Operation is safer and more stable.
- **Operate in low temperatures**
Can be used for cold storage applications in temperatures as low as -10 °C with sealed components impervious to condensation.

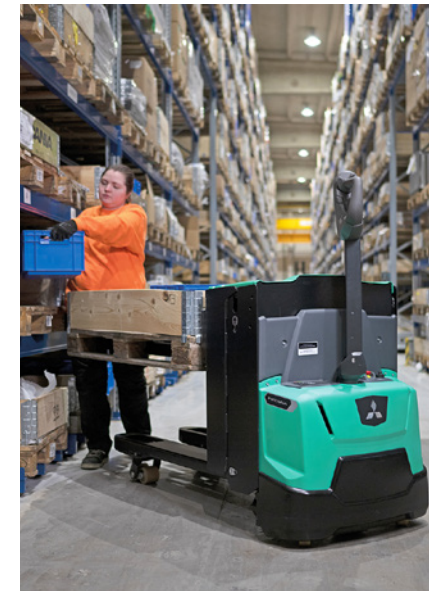

For more information on PREMI^A ES please visit our website



mft2.eu/premiaes

PREMI^A ES

PBP16 - 20N3(R)(E) & PBP12N2D Series

POWER PALLET TRUCK

1.2 – 2.0 tonnes



OPERATOR COMPARTMENT AND CONTROLS

- Choice of two pre-set operating modes (ECO and PRO)**
 Enabled via key switch to enhance safety, energy efficiency and productivity.
- Creep speed function and tiller arm lock bypass**
 Both help to maximise safety and control in confined spaces.
- Unique crossbar design**
 Tiller arm and operator's hand are protected.
- Ergonomic rubber hand grips**
 Handles are comfortable and easy to hold.
- Battery discharge indicator**
 Fitted as standard for battery protection and preventing deep discharge.
- Low to the ground**
 Ground clearance is only 35mm so there is very low risk of foot trapping.
- Spacious platform**
 Suspended foldable platform allows operator to ride in safety and comfort with centre steering. (PBP20N3R)



- Left-handed or right-handed controls**
 The tiller arm's versatile design allows for operation from either side.
- Easy-to-operate tiller arm**
 Its large buttons mean operators can focus on the task in hand and minimise mistakes.
- Multi-function display**
 Shows truck mode, status and drive speeds using easy-to-read icons, as well as error codes. (PBP12N2D).
- Emergency stop**
 Easy and fast stop to power in an emergency.

STEERING SYSTEM

- Ergonomic ErgoSteer tiller head**
 Best-in-class, weather-protected and impact-resistant tiller head with large, easy-to-reach buttons placed at a patented ergonomic distance for reduced fatigue and safer operation. IP65 rated.
- Small turning circle**
 Combine this with the compact chassis and operation is possible in tight areas allowing for optimised use of warehouse space.

OTHER FEATURES

- RapidAccess features**
 These allow quick and easy entry to all areas for checks and maintenance.
- PIN-code access**
 Stops unauthorised truck use and keeps you aware of who's operating at all times. (Option)



For more information on PREMI^A ES please visit our website



mft2.eu/premiaes



PREMIA ES

OPTIONAL LI-ION BATTERY SYSTEMS

MAKE YOUR FORKLIFT GO EVEN FURTHER



Tried, tested and proven in the field, lead-acid batteries have been the long-standing choice for companies employing electric lift trucks. However, with long charging times, demanding maintenance requirements, the need for extra batteries, and high risk of operator misuse, day-to-day use can be a challenge.

Fortunately, there's a new battery system on the block: Li-ion from Mitsubishi Forklift Trucks.

Designed to meet your business' demands — including multi-shift (24/7) operations — without the need for spare batteries, our high-performance Li-ion battery system is up to 30% more efficient than lead-acid counterparts. Plus, it's virtually error-proof, thanks to its ultra-low-maintenance design which prevents cell damage.

- **Gas-emission free**
No need for air ventilation.



Li-ion battery option is available in selected regions. Continuing improvement may lead to changes in these specifications

- **Exceptional high battery and charger efficiency**
State-of-the-art technology delivers up to 30% more power efficiency than lead-acid batteries.
- **Maintenance-free design**
No need for daily checks and water re-fills. This reduces the risk of operators damaging cells and reducing their lifetime. Needs a full charge each week to activate cell balancing.
- **No need for spare batteries or charging room**
You can save both space and costs in multi-shift applications, maximising profitability.
- **Quick charge capabilities**
Just 15 minutes is all your battery needs to keep your truck going for a few more hours. It only takes 1 to 2 hours to fully charge a completely discharged battery.
- **Higher sustained voltage**
This gives more consistent lifting and driving performance — particularly noticeable towards the end of a shift.
- **Multiple safety features**
This includes circuit protection, deep-discharge and overcharge protection, and individual cell temperature and voltage monitoring.
- **On-the-go performance and monitoring**
The system's integrated monitoring system has an easy-to-read display unit.
- **Wide choice of battery and charger capacities**
The most suitable power supply can be matched to the exact requirements of a specific application.



Clean Li-ion batteries are ideal for sensitive environments such as those in the food or packaging industries.

Fully integrated Li-ion battery

Features a sophisticated CANbus communication and an automatic ON/OFF synchronization between battery and truck. Battery level, notifications and alarms are integrated into the truck display, to secure clear and easy overview for the truck operator.

For more information on Li-ion please visit our website



mft2.eu/ion

VDI - PERFORMANCE & DIMENSIONS

CHARACTERISTICS			
1.1	Manufacturer		Mitsubishi Forklift Trucks
1.2	Manufacturer's model designation		PBP12N2D
1.3	Power source		Battery
1.4	Operator type		Pedestrian
1.5	Load capacity	Q	kg 1250
1.6	Load center distance	c	mm 600
1.8	Load wheel axle to fork face (forks lowered)	x	mm 990
1.9	Wheelbase	y	mm 1510
WEIGHT			
2.1	Truck weight without load, with maximum battery weight		kg 800
2.2	Axle loadings with nominal load & maximum battery weight, drive / load side		kg 990 / 1410
2.3	Axle loadings without load & with maximum battery weight, drive / load side		kg 590 / 210
WHEELS, DRIVE TRAIN			
3.1	Tyres: PT = Power Thane, Vul = Vulkollan, P = Polyurethane, N = Nylon, R = Rubber drive / load side		Vul / Vul
3.2	Tyre dimensions, drive side		mm 230 x 70
3.3	Tyre dimensions, load side		mm 85 x 99
3.4	Castor wheel dimensions (diameter x width)		mm 140 x 60
3.5	Number of wheels, load / drive side (x = driven)		1 x + 1 / 4
3.6	Track width (center of tyres), drive side	b10	mm 382
3.7	Track width (center of tyres), load side	b11	mm 355
DIMENSIONS			
4.2a	Height with mast lowered	h1	mm 1400 / 1550
4.4	Lift height	h3	mm 1700 / 2000
4.5	Height with mast extended	h4	mm 2145 / 2445
4.6	Initial lift	h5	mm 120
4.8	Seat- or stand height	h7	mm -
4.9	Height of tiller arm / steering console (min./max.)	h14	mm 913 / 1368
4.15	Fork height, fully lowered	h13	mm 90
4.19	Overall length	l1	mm 1864
4.20	Length to fork face	l2	mm 664
4.21	Overall width	b1/b2	mm 660
4.22	Fork dimensions (thickness, width, length)	s/e/l	mm 65 / 185 / 1200
4.25	Outside width over forks (minimum / maximum)	b5	mm 540
4.32	Ground clearance at center of wheelbase, (forks lowered)	m2	mm 25
4.33c	Working aisle width (Ast) with 1000 x 1200 mm pallets, load crosswise, platform up/down	Ast	mm NA
4.34a	Working aisle width (Ast) with 800 x 1200 mm pallets, load lengthwise	Ast	mm 2532
4.34b	Working aisle width (Ast3) with 800 x 1200 mm pallets, load lengthwise	Ast3	mm 2290
4.34c	Working aisle width (Ast) with 800 x 1200 mm pallets, load lengthwise, platform up/down	Ast	mm
4.35	Turning radius	Wa	mm 1880
PERFORMANCE			
5.1	Travel speed, with / without load	km/h	5.6 / 6
5.2	Lifting speed, with / without load	m/s	0.10 / 0.20
5.3	Lowering speed, with / without load	m/s	0.12 / 0.12
5.7	Gradeability, with / without load	%	6 / 19
5.9	Acceleration time (10 metres) with / without load	s	7.94 / 6.76
5.10	Service brakes (mechanical / hydraulic / electric / pneumatic)		Electric
ELECTRIC MOTORS			
6.1	Drive motor capacity (60 min. short duty)	kW	1.3
6.2	Lift motor output at 15% duty factor	kW	2.35
6.4	Battery voltage/capacity at 5-hour discharge	V/Ah	24 / 150 - 230
6.5	Battery weight	kg	140 - 215
MISCELLANEOUS			
8.1	Type of drive control		Stepless
10.7	Level of noise at the ear level of the driver according to EN 12 053:2001 and EN ISO 4871 in work LpAZ	dB(A)	74.6 +/- 0.7
10.7.1	Level of noise at the ear level of the driver according to EN 12 053:2001 and EN ISO 4871, drive/lift/idle LpAZ	dB(A)	
10.7.2	Whole-body vibration (EN 13 059:2002)		
10.7.3	Hand-arm vibration (EN 13 059:2002)		

PREMIA ES

PEDESTRIAN DOUBLE PALLET TRUCK

PBP12N2D

1.2 tonnes

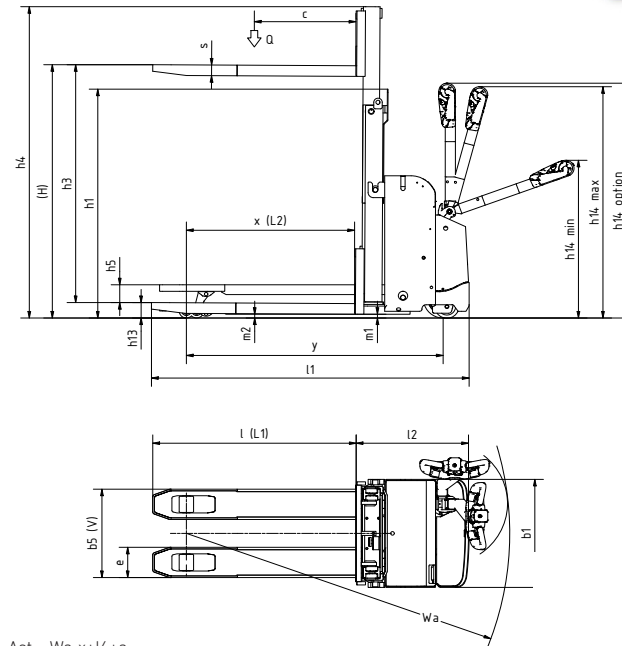

Ast = $Wa - x + l6 + a$
 Ast = Working aisle width
 Wa = Turning radius
 a = Safety clearance (200 mm)
 l6 = Pallet length

h3+h13 = Lifting height
 h1 = Lowered mast height
 h2+h13 = Free lift

MAST TYPE	h3 + h13 mm	h1* mm	h2 + h13 mm
PBP12N2D			
DUPLEX	1790	1400	NA
	2090	1550	NA

Mast Performance and Capacity

h1 = Height with mast lowered
 h2 = Standard free lift
 h3 = Lift height
 h4 = Height with mast raised
 h5 = Full free lift
 Q = Lifting capacity, rated load
 c = Load centre (distance)

* h1 closed mast height includes polycarbonate finger protection. Mast height excl. Finger protection is 1343mm / 1493mm.

VDI - PERFORMANCE & DIMENSIONS

CHARACTERISTICS				Mitsubishi Forklift Trucks	Mitsubishi Forklift Trucks	Mitsubishi Forklift Trucks
1.1	Manufacturer			PBP16N3	PBP18N3	PBP20N3
1.2	Manufacturer's model designation			Battery	Battery	Battery
1.3	Power source			Pedestrian	Pedestrian	Pedestrian
1.4	Operator type					
1.5	Load capacity	Q	kg	1600	1800	2000
1.6	Load center distance	c	mm	600	600	600
1.8	Load wheel axle to fork face (forks lowered)	x	mm	960	960	960
1.9	Wheelbase	y	mm	1360	1425	1425
WEIGHT						
2.1	Truck weight without load, with maximum battery weight		kg	430	500	500
2.2	Axle loadings with nominal load & maximum battery weight, drive / load side		kg	745 / 1290	805 / 1495	840 / 1660
2.3	Axle loadings without load & with maximum battery weight, drive / load side		kg	340 / 90	380 / 120	380 / 120
WHEELS, DRIVE TRAIN						
3.1	Tyres: PT = Power Thane, Vul = Vulkollan, P = Polyurethane, N = Nylon, R = Rubber drive / load side			Vul / Vul	Vul / Vul	Vul / Vul
3.2	Tyre dimensions, drive side		mm	230 x 70	230 x 70	230 x 70
3.3	Tyre dimensions, load side		mm	85 x 90	85 x 75	85 x 75
3.4	Castor wheel dimensions (diameter x width)		mm	100 x 40	100 x 40	100 x 40
3.5	Number of wheels, load / drive side (x = driven)			2 + 1x / 2	2 + 1x / 4	2 + 1x / 4
3.6	Track width (center of tyres), drive side	b10	mm	480	480	480
3.7	Track width (center of tyres), load side	b11	mm	375	375	375
DIMENSIONS						
4.2a	Height with mast lowered	h1	mm	-	-	-
4.4	Lift height	h3	mm	135	135	135
4.5	Height with mast extended	h4	mm	-	-	-
4.6	Initial lift	h5	mm	-	-	-
4.8	Seat- or stand height	h7	mm	-	-	-
4.9	Height of tiller arm / steering console (min./max.)	h14	mm	865 / 1420	865 / 1420	865 / 1420
4.15	Fork height, fully lowered	h13	mm	85	85	85
4.19	Overall length	l1	mm	1650	1710	1710
4.20	Length to fork face	l2	mm	500	560	560
4.21	Overall width	b1/b2	mm	720	720	720
4.22	Fork dimensions (thickness, width, length)	s/e/l	mm	55 / 165 / 1150	55 / 165 / 1150	55 / 165 / 1150
4.25	Outside width over forks (minimum / maximum)	b5	mm	540	540	540
4.32	Ground clearance at center of wheelbase, (forks lowered)	m2	mm	30	30	30
4.33c	Working aisle width (Ast) with 1000 x 1200 mm pallets, load crosswise, platform up/down	Ast	mm	2339	2475	2472
4.34a	Working aisle width (Ast) with 800 x 1200 mm pallets, load lengthwise	Ast	mm	-	-	-
4.34b	Working aisle width (Ast3) with 800 x 1200 mm pallets, load lengthwise	Ast3	mm	-	-	-
4.34c	Working aisle width (Ast) with 800 x 1200 mm pallets, load lengthwise, platform up/down	Ast	mm	2176	2281	2281
4.35	Turning radius	Wa	mm	1510	1551	1551
PERFORMANCE						
5.1	Travel speed, with / without load		km/h	6.0 / 6.0	6.0 / 6.0	6.0 / 6.0
5.2	Lifting speed, with / without load		m/s	0.035 / 0.045	0.030 / 0.035	0.04 / 0.05
5.3	Lowering speed, with / without load		m/s	0.05 / 0.05	0.06 / 0.042	0.05 / 0.06
5.7	Gradeability, with / without load		%	10.0 / 20.0	10.0 / 20.0	10.0 / 20.0
5.9	Acceleration time (10 metres) with / without load		s	-	-	-
5.10	Service brakes (mechanical / hydraulic / electric / pneumatic)			Electric	Electric	Electric
ELECTRIC MOTORS						
6.1	Drive motor capacity (60 min. short duty)		kW	1.0	1.0	1.0
6.2	Lift motor output at 15% duty factor		kW	0.8	0.8	1.2
6.4	Battery voltage/capacity at 5-hour discharge		V/Ah	24 / 150	24 / 250	24 / 250 - 375 ¹⁾
6.5	Battery weight		kg	150	210	210
MISCELLANEOUS						
8.1	Type of drive control			Stepless	Stepless	Stepless
10.7	Level of noise at the ear level of the driver according to EN 12 053:2001 and EN ISO 4871 in work LpAZ		dB(A)	64	64	64
10.7.1	Level of noise at the ear level of the driver according to EN 12 053:2001 and EN ISO 4871, drive/lift/idle LpAZ		dB(A)	66 / 70	66 / 70	66 / 70
10.7.2	Whole-body vibration (EN 13 059:2002)			-	-	-
10.7.3	Hand-arm vibration (EN 13 059:2002)			< 2.5	< 2.5	< 2.5

1) With 375Ah battery the l2 dimension increases 72 mm

PREMIA ES PEDESTRIAN POWER PALLET TRUCK

PBP16/18/20N3

1.6 – 2.0 tonnes

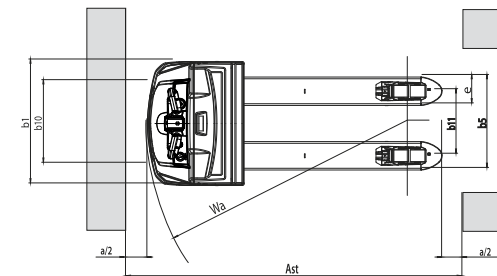
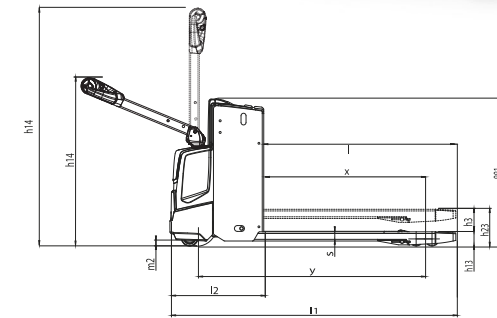

Ast = $Wa - x + l6 + a$
Ast = Working aisle width
Wa = Turning radius
a = Safety clearance (200 mm)
l6 = Pallet length

STANDARD EQUIPMENT & OPTIONS

● = Standard

● = Option

	PBP12N2D	PBP16N3	PBP18N3	PBP20N3	PBP20N3R	PBP20N3E
GENERAL						
Micro-computer incl. hour meter and battery indicator with cut out	●	●	●	●	●	●
PIN code log in 99 codes	●	-	-	-	-	-
PIN code log in 4 codes	-	●	●	●	●	●
Offset tiller arm	●	-	-	-	-	-
Chill store design, down to -10°C, with rust protected axles	●	-	-	-	-	-
Speed regulated lifting and proportional valve for lowering, controlled by rocker switch on tiller head	●	-	-	-	-	-
Electric on/off valve for lifting and lowering, controlled by rocker switch on tiller head	-	●	●	●	●	●
Initial lift	●	-	-	-	-	-
Li-ion batteries*	●	●	●	●	●	●
ENVIRONMENT						
Cold store design, 0C° to -35C° (PBP12N2D, 0C° to -30C°)	●	●	●	●	●	●
Hot operating condition modification, >30C°	-	●	●	●	●	●
DRIVE AND LIFT CONTROLS						
Tiller up drive	●	●	●	●	●	●
WHEEL OPTIONS						
Polyurethan traction and load wheels	●	●	●	●	●	●
Power friction traction wheel	●	●	●	●	●	●
Tandem Polyurethan load wheels	●	●	●	●	●	●
Single Polyurethan load wheels	●	●	●	●	●	●
Non-marking drive wheel	●	-	-	-	-	-
Anti-static drive wheel	●	-	-	-	-	-
OTHER OPTIONS						
Rubber foot protection	●	-	-	-	-	-
Diselectric band	●	-	-	-	-	-
Key switch	●	●	●	●	●	●
Capacity 2000kg on straddles	●	-	-	-	-	-
Piezo buzzer instead of standard horn	●	-	-	-	-	-
Load backrest	●	●	●	●	●	●
Pallet entry and exit rollers	-	●	●	●	●	●
Special RAL colour	●	●	●	●	●	●
Inbuilt charger 30A	●	●	●	●	●	●
Sideways battery change, 250Ah and 375Ah battery only	-	-	●	●	●	-
Battery changing device	-	-	●	●	●	-
Accessory rack	-	●	●	●	●	●
Working light	-	●	●	●	●	●
Multi function display	●	-	-	-	-	-
Battery creep	●	-	-	-	-	-
Battery level audible warning	●	-	-	-	-	-
Service alarm	●	-	-	-	-	-
Automatic log off	●	-	-	-	-	-
Revert to low speed at log off	●	-	-	-	-	-

* Li-ion battery option is available in selected regions.

PREMIA ES

PBP16 - 20N3(R)(E) & PBP12N2D Series

POWER PALLET TRUCK

1.2 – 2.0 tonnes



PIN code log in



Load backrest

WHEN RELIABILITY IS EVERYTHING...



PREMIA
THE NUMBER ONE

Number one for reliability... number one for productivity... whatever the conditions.

Compact, efficient and resilient, PREMIA powered pallet trucks meet every need.

Like any product bearing the "MITSUBISHI" name our materials handling equipment benefits from the tremendous heritage, huge resources and cutting-edge technology of one of the world's largest corporations – Mitsubishi Heavy Industries Group.

Engineering spacecraft, jet planes, power plants and more, MHI specialises in those technologies where performance, dependability and superiority decide your success or failure...

So when we promise you quality, reliability and value for money, you know it's a guarantee we have the power to deliver.

That's why every model in our award-winning and comprehensive range of lift trucks and warehouse equipment is built to a high specification – to ensure it keeps working for you. Day after day. Year after year. Whatever the job. Whatever the conditions.

YOU'LL NEVER WORK ALONE

As your local authorised dealer, we are here to keep your trucks working – through our extensive experience, our technical excellence and our commitment to customer care.

We are your local experts, backed by efficient channels to the entire organisation of Mitsubishi Forklift Trucks.

No matter where you are, we are close by – with the capability to meet your needs.

Discover how Mitsubishi Forklift Trucks give you more from your local authorised dealer or when you visit our website www.mitforklift.com

Performance specifications may vary depending on standard manufacturing tolerances, vehicle condition, types of tyres, floor or surface conditions, applications or operating environment. Trucks may be shown with non-standard options. Specific performance requirements and locally available configurations should be discussed with your distributor of Mitsubishi forklift trucks. We follow a policy of continual product improvement. For this reason, some materials, options and specifications could change without notice.

info@mitforklift.com

WESM2238 (09/22) © 2023 MLE



Mitsubishi Logisnext Europe B.V.
Hefbrugweg 77, 1332 AM Almere
The Netherlands
Tel: +31 (0)36 5494 411



mft2.eu/fb



mft2.eu/apps



mft2.eu/youtube



mft2.eu/facebook

